

General

Version 1.2

C2H4-D3-3V is one of the smallest size Dual Channel Ethylene sensor module in the world. Its Persistent Stability and Temperature Effect Resistance are much favored in flammable and explosion hazard gas and consistent accuracy through the life cycle.

ELT Sensor Data Sheet for C2H4-D3-3V

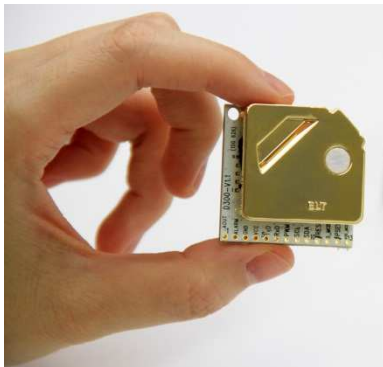

Features

- Non-Dispersive Infrared (NDIR) Dual Channel Technology to measure Ethylene gas sensor levels.
- Excellent compensation of Temperature Effect on gas concentration.
- Output : TTL-UART, I2C, ALARM and PWM (Option: Analog Voltage)
- Easy Calibration with Non-Periodic Manual Calibration (0_MCDL : CAL1) and Periodic Automatic Calibration (0_ACDL : CAL2).
- Size : 33mmx33mmx13.1mm
- Weight : 10 grams

Specifications

Applications

Gas leakage alarming detector or equipment of C2H4, LNG or combustible gases in Mine, metallurgy, liquefied gas station, petroleum, fuel gas ,etc.

General Performance

Operating Temperature : -20 ~ 50°C

Operating Humidity : 0 ~ 95% RH (Non-condensing), 0 ~ 99% RH (Non-condensing) ⁽¹⁾

Storage Temperature : -30°C ~70°C

Measurement

Sensing Method : NDIR (Non-dispersive Infrared)

Measurement Range : 0 ~ 100% LEL (=0~27,000ppm vol. is optional) ⁽²⁾

Accuracy : ±3% of F.S.^{(3),(4),(5)}

Resolution : 1% LEL (= 270ppm)

Detection Limit : 3% LEL (=810ppm)

Step Response Time (90%, 1/e) : 100 seconds / 70 seconds

Sampling Interval: 3 seconds

Warming-up Time : < 6 seconds (for Detection), 5 minutes (for Accuracy)

Electrical Data

Power Input : 3.2V ~3.6 ⁽⁶⁾

Current Consumption : Normal mode : 12mA, Peak : 190mA

Product Derivatives and Relative Functions

Derivatives w/ 3.3V	Feature	Subsidiaries w/ 5V
C2H4-D3-3V	UART,I2C, 1st +2ndALARM, PWM, 0_MCDL(CAL1)/0_ACDL(CAL2)	C2H4-D3
C2H4-D3G-3V	Analog Voltage output , 0_MCDL(CAL1)/0_ACDL(CAL2)	C2H4-D3G

(1) C2H4-D3G-3V : 0 ~ 99% RH (Non-condensing) for Industrial Application of Ethylene gas.

(2) PPM unit output is selectable as option when you designate on issuing order.

(3) 2% should be added for absolute measurements for uncertainty of calibration gas mixture unless '0' ppm or '0'ppm standard gas calibration is done.

(4) Air pressure is assumed as 101.3 kPa.

(5) If sensor is affected by the shock, may need field calibration before installation.

(6) DC Supply should be regulated without ripple < 100mV, low noise power source is needed for best accuracy.

C2H4-D3-3V has various output TTL-UART, I2C, ALARM while as AVO or PWM is selectable as option. 2.54pitch 13pin side hole connector besides 2mm pitch 10 and 4pin 2 row header connectors.

Pin Map with J11&J12 Connectors

J-11	Description
1/3	VDD (+3.2~3.6VDC)
2/4	GND

J-12	C2H4-D3-3V	C2H4-D3-3V (Analog Voltage Option)
1	TTL RXD (← CPU of Master Board)	
2	TTL TXD (→ CPU of Master Board)	
3	I2C SCL	
4	I2C SDA	
5	GND	
6	Reserved	Analog Voltage Output (0.5~3.0V)
7	CAL2-pin : 0_ACDL (for every 7 days ACDL with periodic C2H4-'0'ppm circumstance)	
8	Reserved	
9	CAL1-pin : 0_MCDL (for 2 minutes MCDL with C2H4-'0'ppm- N2-based-gas or Fresh Air)	
10	Reset (Low Active)	

UART 38,400BPS, 8bit, No parity, 1 stop bit
9,600 or 19,200 BPS can selectable through command sets or EK-100SL.

I2C Slave mode only, Internal pull up resister 10kΩ
TTL Level Voltage : $0 \leq V_{IL} \leq 0.4$, $2 \leq V_{IH} \leq V_{DD}$, $0 \leq V_{OL} \leq 0.4$, $2.4 \leq V_{OH} \leq V_{DD}$ (Volt)

ALARM : Open Collector type
ex) Alarm_On : 25% LEL, Alarm-Off : 20% LEL

Analog Voltage: 0.5~3.0V(option)

PWM $t_H = 2 \text{ msec(Start)} + 1,000 \text{ msec} \times (\text{Measurement}_{(\text{ppm})} / \text{Range}_{(\text{ppm})})$, $T_L = 2,000 \text{ ms} - t_H$,

Pin Map with J13 Connectors

J-13	C2H4-D3-3V	C2H4-D3-3V (PWM / Analog Option)
1	Reserved	Analog Voltage Output (0.5~3.0V)
2	1 st Alarm (Open Collector)	
3	GND	
4	VDD (+3.3VDC)	
5	TTL TXD (→ CPU of Master Board)	
6	TTL RXD (← CPU of Master Board)	
7	Reserved	PWM Output (TTL)
8	I2C SCL	
9	I2C SDA	
10	Reset (Low Active)	
11	CAL2-pin (for every 7 days ACDL with periodic C2H4-'0'ppm circumstance)	
12	Reserved	
13	CAL1-pin (for 10 minutes MCDL with C2H4-'0'ppm-N2-based-gas or Fresh Air)	

Cavity Dimensions (unit : mm)

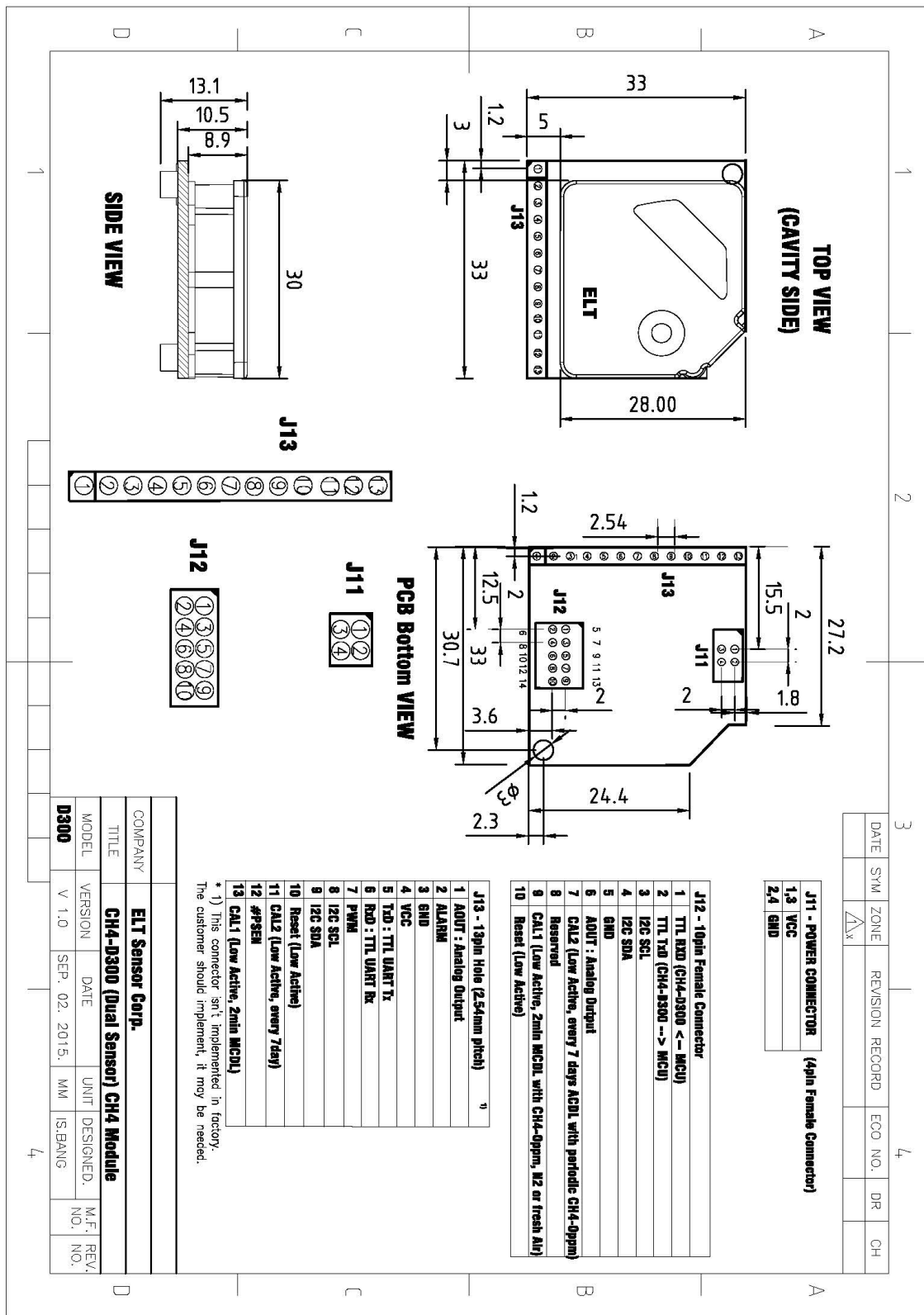

0_MCDL (2 minutes Manual Calibration)

'0' ppm Manual Calibration can be done by giving start command or low signal to CAL1-pin at least more than 2 minutes since the fresh air is fully balanced near sensor.

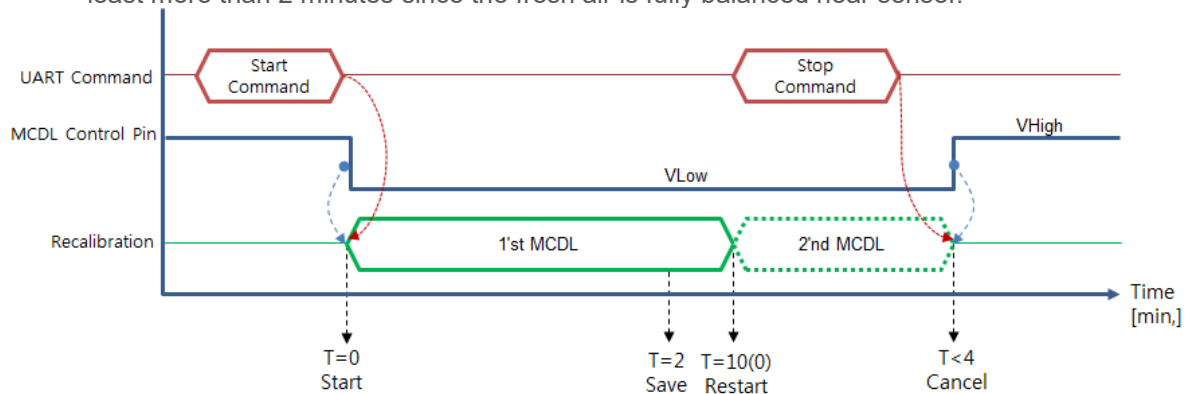

0_ACDL (Periodic Automatic Calibration)

'0' ppm Periodic Automatic Calibration can be used by giving start command or low signal to CAL2-pin. The sensor calibrate automatically first in 2 days, seconds 5 days and every week. '0'ppm Standard Gas can be used when the place doesn't face free air during the period.

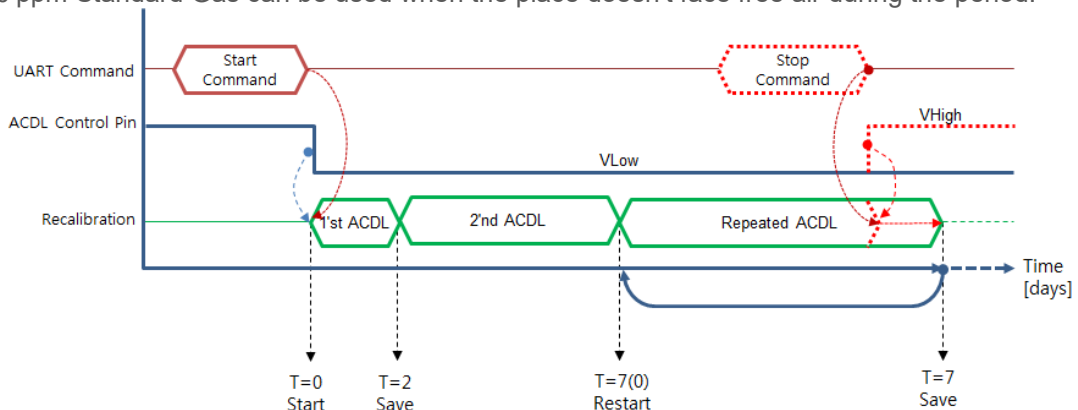

Method 1. UART Command Set; J12: pin-1 (UART-RX) and pin-2 (UART-TX) to Main-Board (J13: pin-5 and pin-6 are available as well.)

Method 2. I2C Command Set; J12: pin-3 (SCL) and pin-4 (SDA) to Main-Board. (J13: pin-8 and pin-9 are available as well.)

Method 3. Let Sensor install on Jig Board, **TRB-100ST (Test and Recalibration Board)** with ambient air-flow condition or with 0'ppm Standard Gas and execute by moving jumper following Manual on the website.

Method 4. Send string command set below to RXD-pin of Sensor on Emulation program.

EK-100SL (Evaluation kit, with Emulation program 'ELTWSO') is available

Method 5. CAL1 / CAL2-pin settings for 0_MCDL / 0_ACDL

CAL1 0_MCDL	CAL 2 0_ACDL	Function	Process
Low	High	H/W '0'ppm MCDL	Let Ethylene gas sensor be located at ambient place where no Ethylene gas exist and wait 2 minute. '0'ppm Standard gas can be used when '0'ppm is not guaranteed.
High	Low	H/W '0' ppm ACDL	Automatic Calibration can be used where sensor faces the clear air more than 3 minutes per week.
High	High	Normal	Operate with Factory Calibrated or previously set status

- ※ 1. CAL-1pin and CAL-2pin shouldn't have 'Low' at the same time.
- 2. Be sure to escape MCDL fetch loop between 2 minutes and 4minutes to avoid inappropriate calibration.

Output Descriptions

UART Descriptions

Data Format

SP	SP	SP	D2	D1	'%	SP	'L'	'E'	'L'	CR	LF
SP x 3			Space: 0x20								
D2 ~ D1			2 byte Ethylene gas density string								
%			% : 0x25								
SP			Space: 0x20								
'LEL'			'LEL' string								
CR			Carriage return : 0x0D								
LF			Line feed : 0x0A								

Above 12byte consist by 2 byte hexadecimal digits, <SP>,<SP>,<SP>, D2, D1, 0x25, <SP>, 'L', 'E', 'L', <CR><LF> , where decimal '0' (corresponds to hexadecimal digit '0x30') is replaced by space (corresponds to hexadecimal digit '0x20'),

EX) 12% LEL (= 3,500 ppm) string is '0x20 0x20 0x20 0x31 0x32 0x25 0x20 0x4C 0x45 0x4C, 0x0D

0x0A',, of which display on the screen is ' ___12%_LEL<CR><LF>'.

'ppm' display is Option on sale, which D6~D1 string display the gas concentration of

D6	D5	D4	D3	D2	D1	SP	'p'	'p'	'm'	CR	LF
----	----	----	----	----	----	----	-----	-----	-----	----	----

EX) 3,500 ppm string is '0x20 0x20 0x33 0x35 0x30 0x30 0x20 0x70 0x70 0x6D 0x0D 0x0A', of which display on the screen is ' __3500__ppm<CR><LF>'.

I2C Communication (Only Slave Mode Operation)

Internal pull up resister 10kΩ

Slave Address: 0x31, Slave Address Byte: Slave Address(0x31) 7 Bit + R/W 1 Bit

Bit7	Bit6	Bit5	Bit4	Bit3	Bit2	Bit1	Bit0
0	1	1	0	0	0	1	R/W Bit

R/W Bit : Read = 1/Write = 0

When reading the data, Slave Address Byte is 0x63, When writing the data, Slave Address Byte is 0x62.

Block Diagram

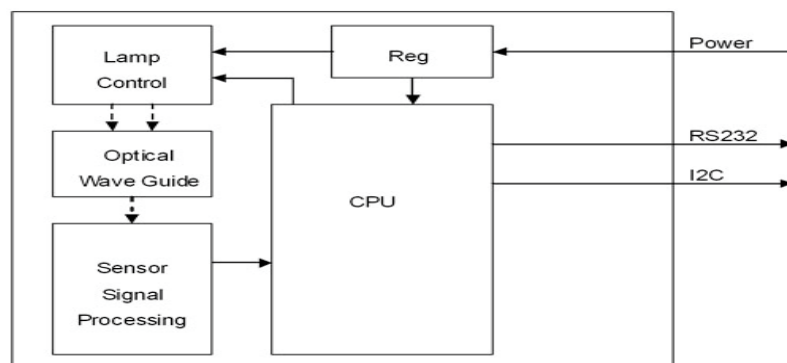

Transmission Sequence in Master

- 1) I2C Start Condition
- 2) Write Command(Slave Address + R/W Bit(0) = 0x62) Transmission and Check Acknowledge
- 3) Write Command(ASCII 'R' : 0x52) Transmission and Check Acknowledge
- 4) I2C Stop Command

- 5) I2C Start Command
- 6) Read Command(Slave Address + R/W Bit(1) = 0x63) Transmission and Check Acknowledge
- 7) Read 7 Byte Receiving Data from Module and Send Acknowledge
(Delay at least 1ms for reading each byte)

Header 1 Byte	C2H4 2 Byte	reserved 0x00	reserved 0x00	Reserved 0x00	reserved 0x00								
<table border="1"> <tr> <td>0</td><td>0</td><td>0</td><td>0</td><td>1</td><td>0</td><td>0</td><td>0</td> </tr> </table>		0	0	0	0	1	0	0	0				
0	0	0	0	1	0	0	0						

In need of detail protocol specification and time sequence, 'I2C programming guide' could be provided by contacting Sales Rep.

Alarm Descriptions

Alarm signal operates as Open Collector type and send TTL on signal since Ethylene gas sensor measured value beyond 25% LEL until it go down to 20% LEL. It is designed to be activated when sensor measured value surpass 25% LEL and deactivated down to 20%LEL to avoid unwanted rapid switching by hysteresis effect.

Alarm_On : 25% LEL, Alarm-Off : 20% LEL

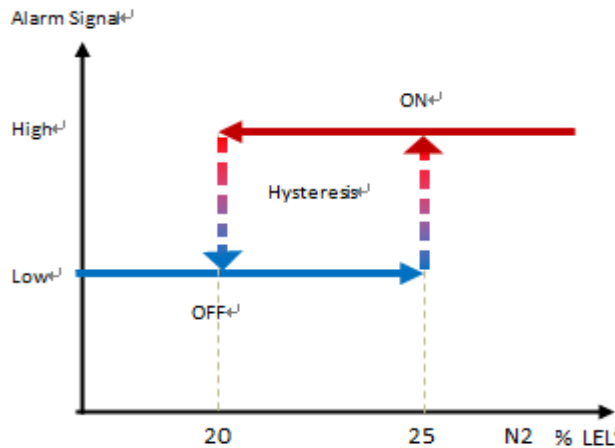

2nd Alarm use V_{OL} / V_{OH} TTL signal Switching instead of SPST (Single Pole Single Throw) method. EK-100SL series is available for customer to enable to change alarm activation & deactivation point.

PWM Descriptions

* Measurement_(ppm) = (t_H-2msec)/1000msec x Range(% LEL) (t_H : High Pulse Width)

* Range_(ppm) : 0~100% LEL (=0~27,000ppm)

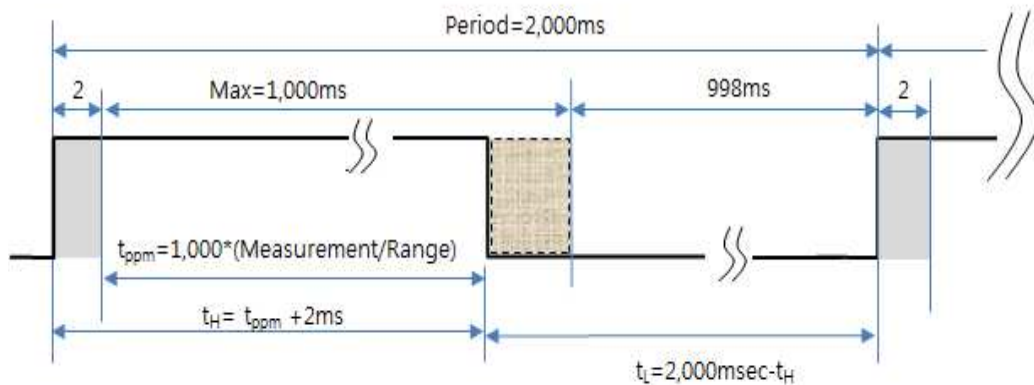

EX) t_H (High Pulse Width) calculation for 50% LEL in 0~100% LEL Range.

* Measurement_(% LEL) = 50% LEL = (t_H-2ms)/2,000msec x Range(% LEL) ,

* t_H = 1,000 msec * (50% LEL / 100% LEL) + 2msec = 502msec

(cf: T_L = Period - t_H = 2,000 msec - 502 msec = 1,498 msec.)

Analog Voltage Output Descriptions

Measured Voltage 0.5V~3V match proportionally to 0 ~ 100% LEL.

* Measurement_(ppm) = Output Voltage - 0.5 / (3 - 0.5) Voltage X 100% LEL.

EX) if the Output Voltage is 1.25V in 0~100% LEL range,

Ethylene gas (% LEL) = (1.25 - 0.5) V ÷ (3 - 0.5)V x 100% LEL

= 0.5 x 100% LEL = 50% LEL

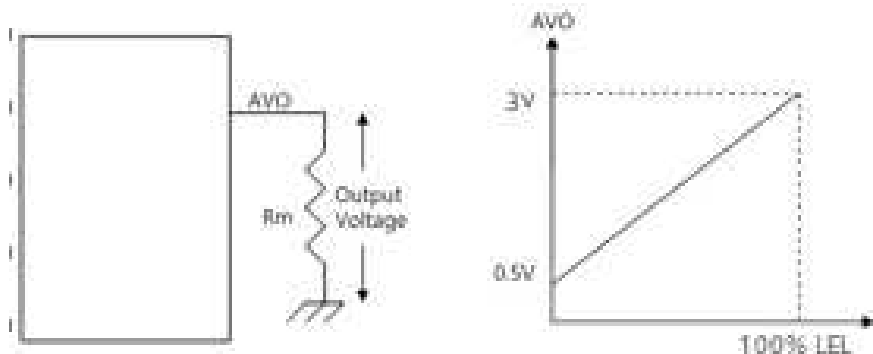

※ **Caution**

1. The gold cavity part of the sensor module or the PCB outer part should not touch by the customer's case housing. It causes long-term value fluctuation. Be at least 3 mm apart from the housing.
2. When removing and inserting the sensor module, do not hold the gold cavity but hold the PCB on both sides. Put on the electret gloves to prevent the static electricity.
(Excessive force on the gold cavity can affect the initial performance and accuracy of the sensor.)
→ If the measured value is wrong, you can calibrate zero point for more than 10 minutes at CAL1 (MCDL) position and use it with high accuracy.
3. Do not let water get on, drop, or shock the sensor.
4. Do not store the sensors in high temperature and high humidity for long time without applying power. The initial measurement accuracy of the sensor may be affected.
5. Be careful not to be affected by static electricity and induction electromagnetic field around sensor.
To prevent static electricity from being generated during assembly, wear electrostatic gloves and work on a static-free workbench. (Keep the sensor in the place where the electricity is removed.)
6. Install the sensor at a position as far away as possible from the motor or vibration. Vibration or noise may be accuracy affected during sensor operation.
7. When using the sensor for the first time or after long term storage, you can use 0_MCDL / 0_ACDL Zero point calibration and use it with high accuracy.

※ Specification of C3H8-D3-3V Series could be changed without notice.